

Manufacturers of Quality Ram & Diaphragm Pumps to the Water Treatment and Process Industries

Energy Pumps Benefits

- British Manufacturer of Heavy Duty Diaphragm and RAM Piston Pumps
- Reducing CAPEX and OPEX Cost
- Self Priming and Can Dry Run
- Handles Thick Sludges with Rag and Grit Content
- All Spares Held on Stock for Fast Response

Suitable For

- Desludging Sedimentation Tanks
- Sludge/Sewage Transfer
- Farm and Agricultural Slurries
- Quarry/Potteries Slurry
- Paper and Pulp
- Food Waste/Slurries
- Chemical/petrochemical
- Railways (toilet emptying)

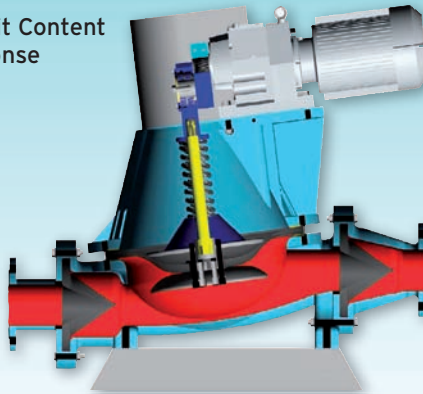

PROMOTION!

To celebrate Energy Pumps 30th birthday, we're giving away one of the latest TOMTOM 740 LIVE Satnav systems - worth over £300.

All genuine enquiries for pumps received by 31st August 2009 will be entered into the draw. Please quote ref. WWTW0509 in your quotation request. The draw will be held on 31 August 2009, and the results shown on our website.

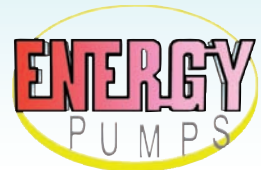

Tel: 01636 816600
Fax: 01636 816602
sales@energypumps.co.uk
www.energypumps.co.uk